

INSTALLATION MANUAL

PRODUCT NAME : Glare Shield Cap.

No.	Accessory Name	Ordering Code	Dimension	
			A	B
1.	Glare Shield Cap. [for Mini SPACE]	AUN-GHS-0033-XX	Ø250	116

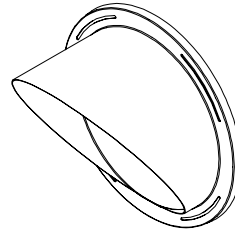
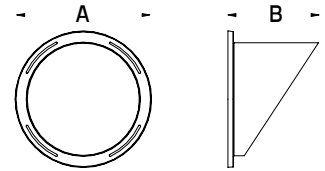

1

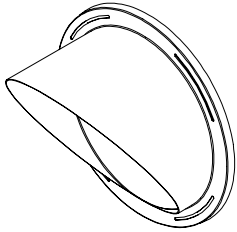

Part/ชิ้น : A

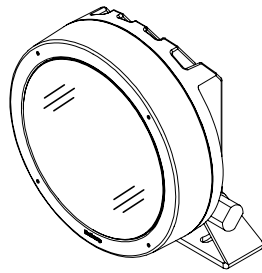

Part/ชิ้น : B

2

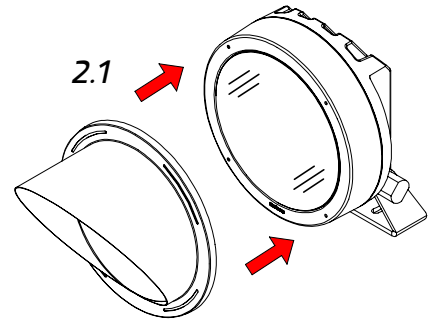

Torque/แรงบิด : 0.5 Nm.

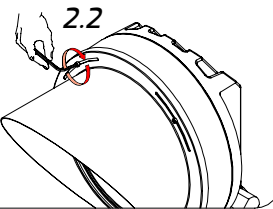

3

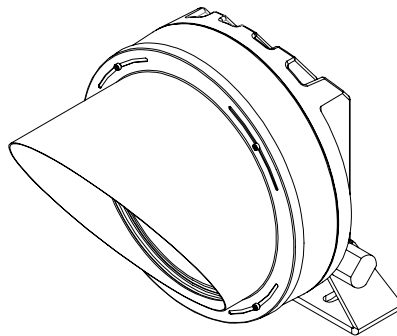

Installation complete
การติดตั้งเสร็จสมบูรณ์