

INSTALLATION MANUAL

PRODUCT NAME : Glare Shield Cap

No.	Ordering Code	Accessories Name
1.	0206-0-9-000-XX	Glare Shield Cap for KUBIK
2.	0243-0-9-000-XX	Glare Shield Cap for FIN
3.	0267-0-9-000-XX	Glare Shield Cap for Mini KUBIK

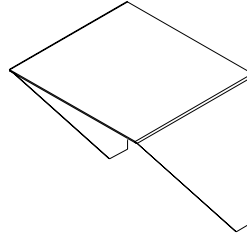

1

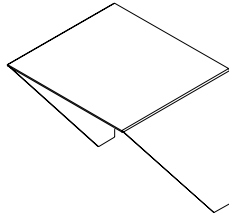

Part/ชิ้น A

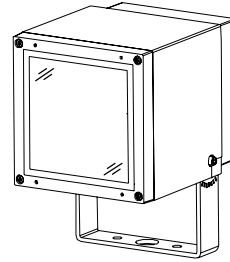

Part/ชิ้น B

2

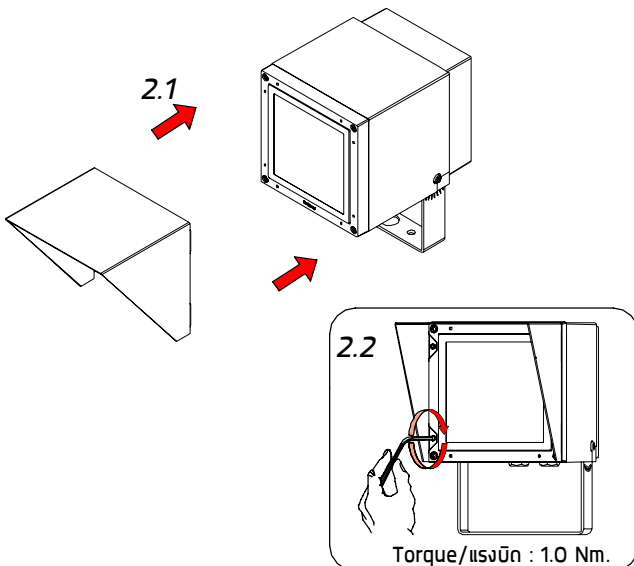

3

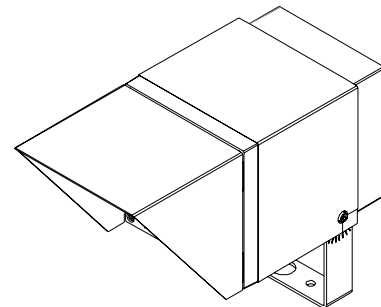

Installation complete  
การติดตั้งเสร็จสมบูรณ์