

TUBE

MEDIUM TUBE

CEILING RECESSED



LAST UPDATE: 30-05-2024



TUBE a family of cylindrical shaped wall light, ceiling light and Area light. The body components are made from extruded and LM6 aluminium which make them highly corrosion resistant to any extreme environment. TUBE is protected from the ingress of dust and water and are used in both outdoor and indoor environments. Fitted with COB LED in three color temperature from 2700K, 3000K or 4000K with high CRI. HID light source and retrofit solution for E27 Led lamps are also available. TUBE can solve many lighting tasks in modern architectural surrounds and are generally used in illuminating columns and facades. The pole lights give a great level of downward light with symmetric wide beam, asymmetric forward throw or side throw light distributions. Catenary mounting of luminaires is great option for tasteful illumination of outdoor spaces. Flexible arrangement of the luminaire position enables lighting designers to set the light mood to a multitude of use cases. The innovative lever clamping system utilizes a single common tool for a trouble free easy installation. All commonly used catenary wires with a diameter of 4...8mm are suitable. Wire slope of up to 20° can be easily compensated. Catenary mount luminaires are equipped with a single prewired cable of 2000mm length. Double prewired cable for looping is available upon request.



Technical Data



Ordering Code :	7350-6-4-505-XX
Lamp :	LED
Beam :	23°
CCT :	2700 K
CRI :	CRI >80
SDCM :	SDCM = 3
Lamp Lumen :	2300 lm
Luminaire Lumen :	2080 lm
Lamp Wattage :	16 W
Luminaire Wattage :	20 W
Efficacy :	104 lm/W
Ambient Temperature :	50°C
Lumen Maintenance	L70B10 >90,000 h
Controller :	DIM 1-10V
Input Voltage :	220-240Vac 50/60Hz
Net Weight :	2.30 kg.

Ordering code guide

XXXX-X-X-XXX-XX
A B C D E

- A Product Code
- B Reflector
- C Electrical Component
- D Lamp
- E Color



Icon definition

*Due to the constancy of product development, we reserve the right to alter all specification without prior notice.

Unilamp Co., Ltd.
461 Ramintra Road, Kannayao, Bangkok 10230 Thailand
Tel : +66(0)2 943 2420-1, +66(0)2 946 4170-1
Fax : +66(0)2 943 2419
online@unilamp.co.th
www.unilamp.co.th

TUBE

MEDIUM TUBE

CEILING RECESSED



LAST UPDATE: 30-05-2024

Specification

IEC Standard	IEC 60598-1 General Requirement IEC 60598-2-1 Fixed Luminaires
Protection	IP65 Class I
Luminaires Body Housing	High-pressure die cast aluminum alloy body and components. Extruded aluminum 56063 alloy body with low copper content.
Coating Process	Nano Ceramic surface conversion, resistant to corrosive environment. Luminaire primarily coated with epoxy resin and top coated with UV stabilized polyester powder and cured in digital temperature controlled chamber at 200°C.
Diffuser	Impact resistant safety tempered glass cover. Able to withstand the temperature up to 250°C.
Reflector	High performance anodized spun aluminum reflector.
Gasket	Post-cured treated silicone gasket. Temperature and weather resistant. Working temperature -40°C to +200°C.
External Screws	External screws are in stainless steel with protection grease.
Cable Entry	Cable entry protected by weather proof grommet. To be used with HO5RN-F/ HO7RN-F cable with 6-13mm. diameter.
Led	High efficiency LED module in COB technology. Assembled on MCPCB and mounted on to heat conductive material.
Driver	High quality Dimmable Driver (1-10V) in constant current. Conform to applicable safety standards and electromagnetic compatibility.
Internal Wire	Tinned copper conductor with silicone insulated internal wire. IMQ approved. Working temperature -40°C to +180°C.
Terminal Block	Terminal block in GFR PA6.6 for cable with cross section up to 2.5 sqmm. VDE approved. Class1 luminaire provided with the earth connection.
Caution	Installation work has to be carried on according to the enclosed installation manual.
Color	 <ul style="list-style-type: none">Black O1Graphite O2Dark Grey O3Aluminum Silver O4White O6Wooden Brown O7

Light Distribution

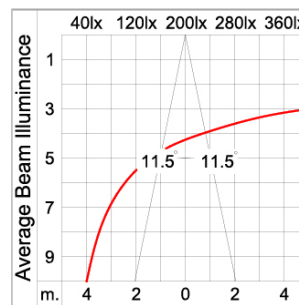
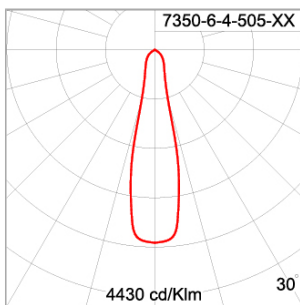

*Due to the constancy of product development,
we reserve the right to alter all specification
without prior notice.

Unilamp Co., Ltd.
461 Ramintra Road, Kannayao, Bangkok 10230 Thailand
Tel : +66(0)2 943 2420-1, +66(0)2 946 4170-1
Fax : +66(0)2 943 2419
online@unilamp.co.th
www.unilamp.co.th

TUBE

MEDIUM TUBE

CEILING RECESSED



LAST UPDATE: 30-05-2024

Accessories



Ordering Code:
AUN-GHS-0025-00
Glare shield ring, COB



Ordering Code:
AUN-CAB-0003-00
Cable 3x1sqmm and
2x0.35sqmm, L= 2000,
with UniBlock
anti-humidity kit,
pre-assembly from factory

*Due to the constancy of product development,
we reserve the right to alter all specification
without prior notice.

Unilamp Co., Ltd.
461 Ramintra Road, Kannayao, Bangkok 10230 Thailand
Tel : +66(0)2 943 2420-1, +66(0)2 946 4170-1
Fax : +66(0)2 943 2419
online@unilamp.co.th
www.unilamp.co.th