

VISTA

VISTA

SPOTLIGHT



LAST UPDATE: 19-05-2026

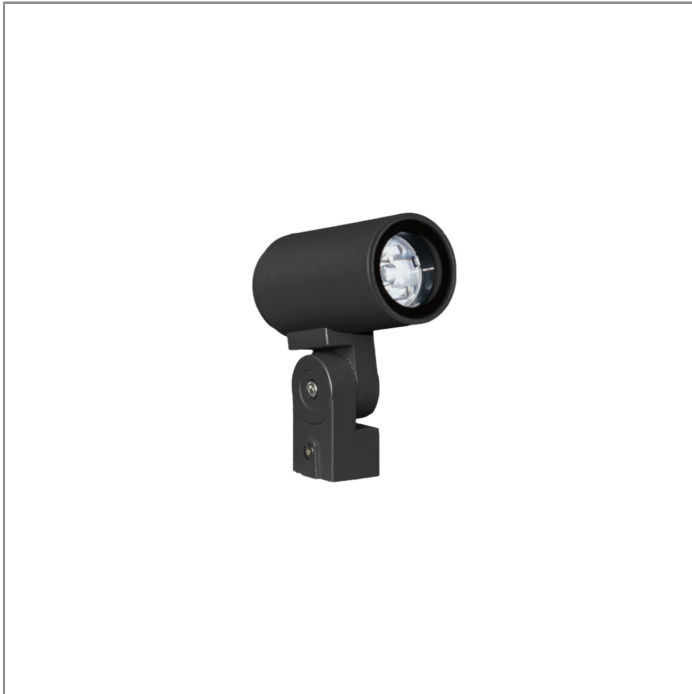

VISTA is a compact and versatile spotlight designed for outdoor architectural and landscape applications. Its clean cylindrical form and minimal footprint allow for easy integration. The housing is made from corrosion-resistant die-cast aluminum, while high-quality optical components ensure precise beam control with multiple distribution options. VISTA supports ON/OFF operation and can be customized with accessories such as honeycomb louvres, glare shield cap, and short snoot for enhanced visual comfort and light control. The simple mounting system and durable construction make it ideal for both residential and commercial environments where reliability and ease of installation are essential.

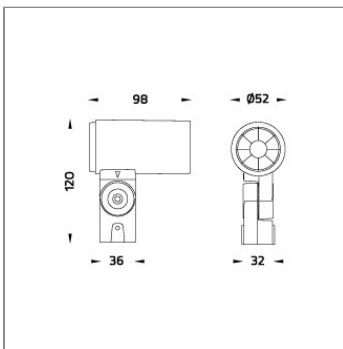

Technical Data



Ordering Code :	5930-B-3-017-A1
Lamp :	COB LED
Beam :	27°
CCT :	3000 K
CRI :	CRI >80
SDCM :	SDCM = 3
Lamp Lumen :	550 lm
Luminaire Lumen :	400 lm
Lamp Wattage :	4.3 W
Luminaire Wattage :	5 W
Efficacy :	80 lm/W
Ambient Temperature :	50°C
Lumen Maintenance	L70B10 >54,400 h
Controller :	On-Off
Input Voltage :	220-240Vac 50/60Hz
Net Weight :	- kg.

Ordering code guide

XXXX-X-X-XXX-XX

- A Product Code
- B Reflector
- C Electrical Component
- D Lamp
- E Color



Icon definition

*Due to the constancy of product development, we reserve the right to alter all specification without prior notice.

Unilamp Co., Ltd.
461 Ramintra Road, Kannayao, Bangkok 10230 Thailand
Tel : +66(O)2 943 2420-1, +66(O)2 946 4170-1
Fax : +66(O)2 943 2419
online@unilamp.co.th
www.unilamp.co.th

VISTA

VISTA SPOTLIGHT



LAST UPDATE: 19-05-2026

Specification

IEC Standard	IEC 60598-1 General Requirement IEC 60598-2-1 Fixed Luminaires
Protection	IP65 Class I
IK Rating	Protection against mechanical impact IK09 on body and IK06 on optical part.
Luminaires Body Housing	Durable high-pressure die-cast aluminum alloy for excellent mechanical performance.
Coating Process	The luminaire undergoes a Nano Ceramic surface conversion, making it highly resistant to corrosive environments. It is primarily coated with a durable epoxy resin and finished with a UV-stabilized polyester powder top coat. The coating process is completed by curing the luminaire in a digitally controlled temperature chamber at 200°C, ensuring exceptional durability and long-lasting protection aga
Diffuser	Impact-resistant tempered glass designed for high-temperature environments.
Lens	Advanced molded PC lens offering diverse light distribution patterns.
Adjustable Optic	Adjustable aiming mechanism with graduated scale for precision control.
External Screws	Durable stainless steel screws with anti-corrosion grease for extended lifespan.
Led	COB LED module with high efficiency, mounted on MCPCB for superior thermal management.
Driver	Certified constant current LED driver meeting all EMC and safety requirements.
Internal Wire	Reliable silicone-insulated tinned copper internal wire, designed for -40°C to +180°C.
Pre-Wire Cable	Certified pre-wired 3x0.75 sqmm cable, featuring HO5RN-F neoprene insulation.
Caution	Installation must be performed as per the provided installation instructions.

Light Distribution

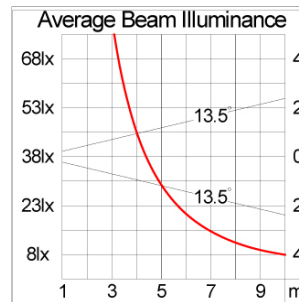
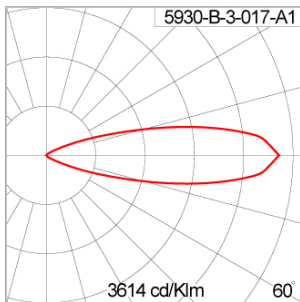

*Due to the constancy of product development, we reserve the right to alter all specification without prior notice.

Unilamp Co., Ltd.
461 Ramintra Road, Kannayao, Bangkok 10230 Thailand
Tel : +66(0)2 943 2420-1, +66(0)2 946 4170-1
Fax : +66(0)2 943 2419
online@unilamp.co.th
www.unilamp.co.th

VISTA

VISTA

SPOTLIGHT

 **Unilamp**

LAST UPDATE: 19-05-2026

Accessories

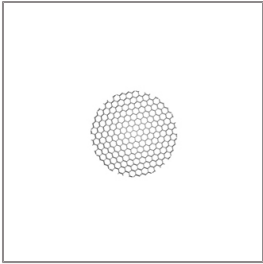

Ordering Code:
ATR-GSH-0005-00
Honeycomb louver, LED,
pre-assembly from factory

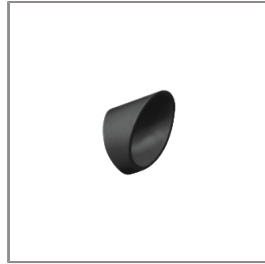

Ordering Code:
ATR-GSH-0003-XX
Glare shield cap



Ordering Code:
ATR-ESP-0002-00
Earth spike, polymer

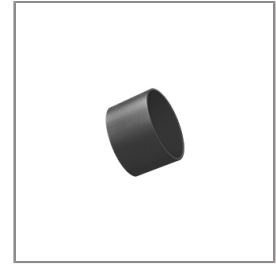

Ordering Code:
ATR-GSH-0004-XX
Short snoot

*Due to the constancy of product development,
we reserve the right to alter all specification
without prior notice.

Unilamp Co., Ltd.
461 Ramintra Road, Kannayao, Bangkok 10230 Thailand
Tel : +66[0]2 943 2420-1, +66[0]2 946 4170-1
Fax : +66[0]2 943 2419
online@unilamp.co.th
www.unilamp.co.th